

Auger Tube Restrictor Kit

Tailgate Spreaders

PARTS LIST

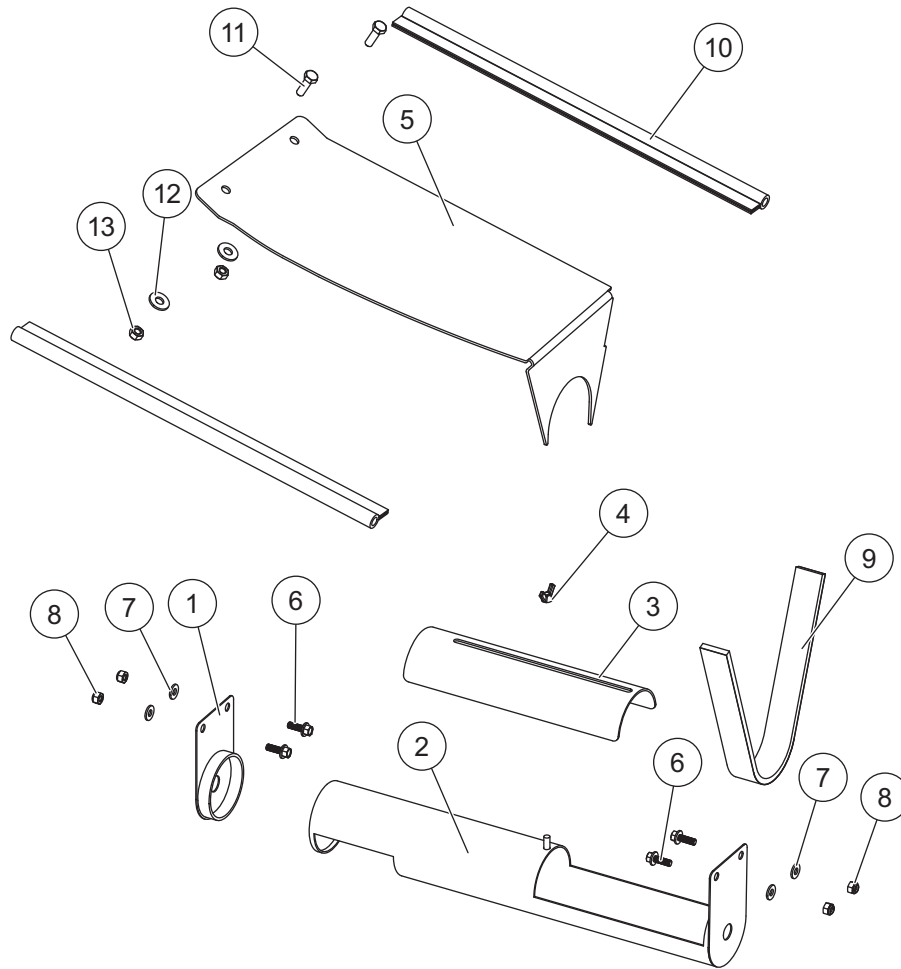

TRK-1875, 75914 Auger Tube Restrictor Kit							
Item	Part	Qty	Description	Item	Part	Qty	Description
1	D5957	1	Auger End Cap	8		4	1/4-20 Hex Locknut SS
2	D5955	1	Auger Tube	9	T30012	1	Foam, 18"
3	D5958	1	Gate Slide	10	T30008	1	Edge Grip Seal, 36"
4		1	1/4-20 Wing Nut SS	11		2	5/16-18 x 1 Hex Cap Screw
5	D5988	1	Material Baffle	12		2	5/16 Flat Washer
6		4	1/4-20 x 3/4 Hex Cap Screw Serrated Flange SS	13		2	5/16-18 Hex Locknut
7		4	1/4 Flat Washer SS	ns		11	1/4 x 3/4 x 1/2 Retainer, Black
				ns		6	3/16 x .354 Rivet, Black Aluminum
ns = not shown				SS = Stainless Steel			

⚠ WARNING

Do not exceed GVWR or GAWR ratings as found on the driver-side vehicle door cornerpost.

⚠ CAUTION

Read this document before installing the auger tube restrictor kit.

⚠ CAUTION

Use standard methods and practices when attaching spreader and installing accessories, including proper personal protective safety equipment.

Recommended Fastener Torque Chart

Inch Fasteners Grade 5 and Grade 8

Size	Torque (ft-lb)		Size	Torque (ft-lb)	
	Grade 5	Grade 8		Grade 5	Grade 8
1/4-20	8.4	11.9	9/16-12	109	154
1/4-28	9.7	13.7	9/16-18	121	171
5/16-18	17.4	24.6	5/8-11	150	212
5/16-24	19.2	27.3	5/8-18	170	240
3/8-16	30.8	43.6	3/4-10	269	376
3/8-24	35.0	49.4	3/4-16	297	420
7/16-14	49.4	69.8	7/8-9	429	606
7/16-20	55.2	77.9	7/8-14	474	669
1/2-13	75.3	106.4	1-8	644	909
1/2-20	85.0	120.0	1-12	704	995

Metric Fasteners Class 8.8 and 10.9

Size	Torque (ft-lb)		Size	Torque (ft-lb)	
	Class 8.8	Class 10.9		Class 8.8	Class 10.9
M6 x 1.00	7.7	11.1	M20 x 2.50	325	450
M8 x 1.25	19.5	26.9	M22 x 2.50	428	613
M10 x 1.50	38.5	53.3	M24 x 3.00	562	778
M12 x 1.75	67	93	M27 x 3.00	796	1139
M14 x 2.00	107	148	M30 x 3.50	1117	1545
M16 x 2.00	167	231	M33 x 3.50	1468	2101
M18 x 2.50	222	318	M36 x 4.00	1952	2701

These torque values apply to fasteners except those noted in the instructions.

INSTALLATION INSTRUCTIONS

1. Park the vehicle on a smooth, level, hard surface, such as concrete. Turn the vehicle ignition to the "OFF" position and remove the key.
2. Empty hopper of all material. Remove the spreader power plug from truck wire harness. Ensure spreader is not powered. If desired, remove spreader from truck for ease of access to auger and baffle components.

Disassembly

1. Remove cover and top screen. Set them and all associated hardware aside.
2. Remove the inverted "V" and baffle. The vibrator mounting plate does not have to be removed. Make sure the auger set screw is visible.

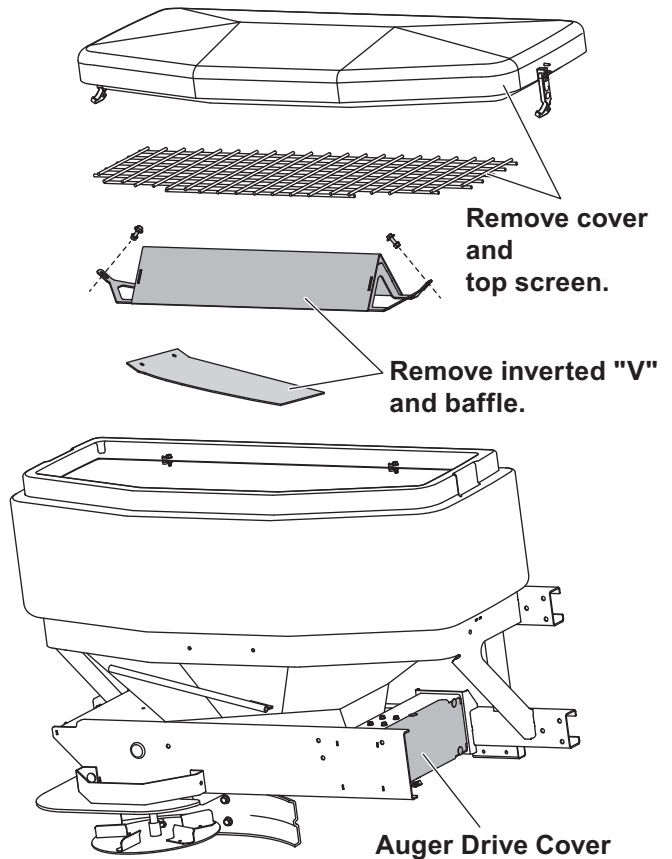

- Remove the auger and spinner drive covers. Set the covers and all associated hardware aside.

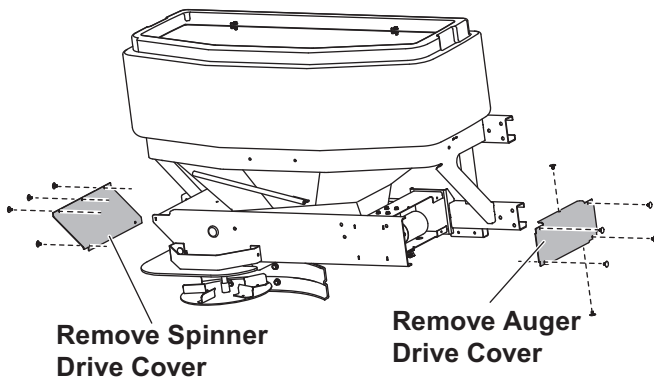

- In the spinner drive box there are two set screws that need to be loosened. Loosen the auger set screw as well. The set screw is located on the auger in the spreader tub.
- Remove all four bolts that hold the gearbox to the hopper frame. Slide the motor and gearbox out of the frame. This allows the auger to be removed from the tub.

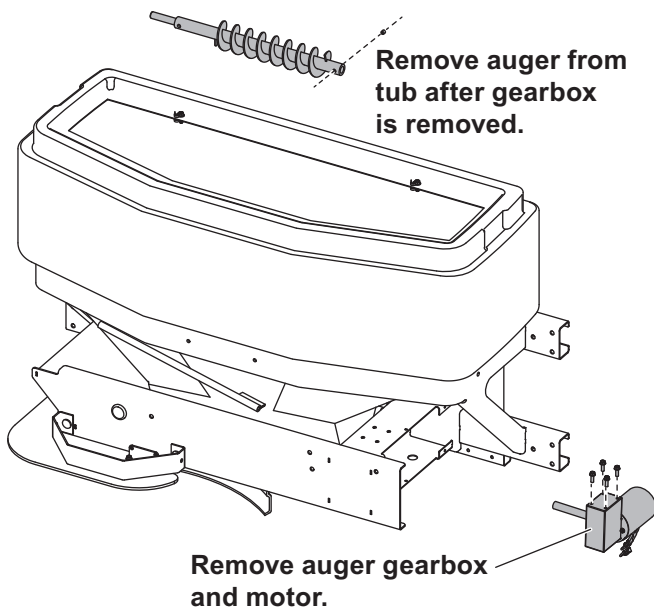

Reassembly/Installation

- Remove the auger and slide it into the auger tube. Place the end cap on the auger tube and install the foam seal as needed to prevent material from falling out of the auger tube. Replace all components back into the spreader tub in the reverse order that they were removed.

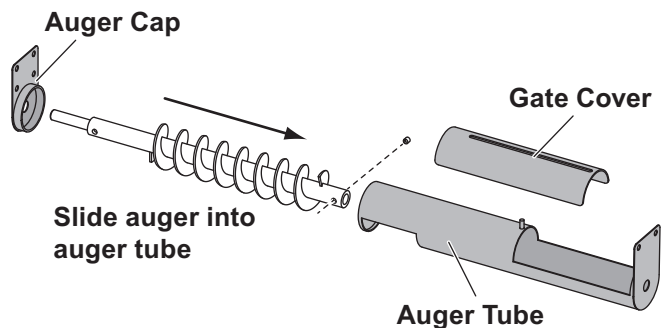

- Install the motor and gearbox back into the frame. Be sure the auger is seated properly in the spinner side bearing so the set screws can be tightened. The gearbox output shaft will slide into the auger as before. Install hardware to the gearbox and frame; tighten all fasteners finger tight. Make sure the auger set screw is on the flat of the gearbox output shaft and tighten it down. Once the auger set screw is fully tightened, tighten the gearbox mount bolts according to the torque chart.

⚠ CAUTION

Before drilling holes, check to be sure that no vehicle wiring or other components could be damaged.

- Position the auger and tube so that they both sit unobstructed in the hopper tub. Once the tube is positioned, mark the mounting holes on the auger and spinner drive hopper tub side wall positions. Drill 5/16" holes in designated spots and insert hardware. Tighten all fasteners according to the torque chart.

- Place the gate cover over the auger tube and set to desired opening. Secure it in place with the provided wing nut and weld bolt.

⚠ CAUTION

Before drilling holes, check to be sure that no vehicle wiring or other components could be damaged.

- Install rubber seals on both sides of the baffle. Set the baffle from the kit in the hopper tub with the bottom against the auger tube. Mark and drill new 5/16" holes for the baffle to attach to the hopper tub.

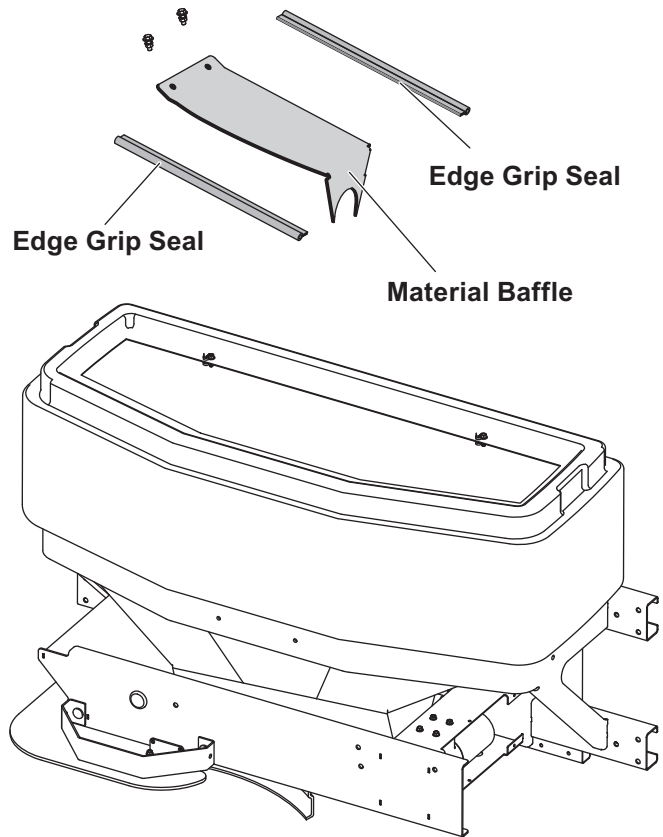

- Reinstall the auger drive cover with the supplied black push retainers. Reinstall the top screen and spreader top.

Copyright © 2016 Douglas Dynamics, LLC. All rights reserved. This material may not be reproduced or copied, in whole or in part, in any printed, mechanical, electronic, film or other distribution and storage media, without the written consent of the company. Authorization to photocopy items for internal or personal use by the company's outlets or spreader owner is granted.

The company reserves the right under its product improvement policy to change construction or design details and furnish equipment when so altered without reference to illustrations or specifications used. This equipment manufacturer or the vehicle manufacturer may require or recommend optional equipment for spreaders. Do not exceed vehicle ratings with a spreader. The company offers a limited warranty for all spreaders and accessories. See separately printed page for this important information.

Printed in U.S.A.